

SECTION A-A (CURB RAMP TYPE 1 AND 2)

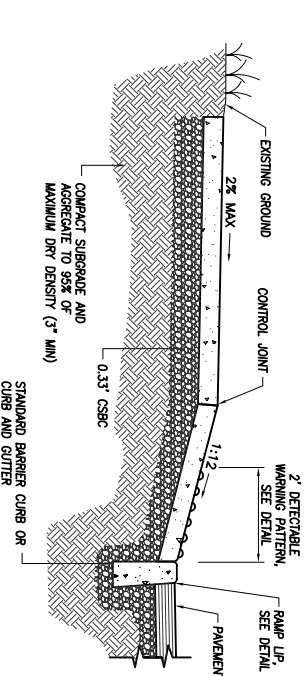

SECTION B-B (CURB RAMP TYPE 3, 4 AND 5)

- NOTES:
1. WHEEL CHAIR RAMPS WILL BE PLACED AT ALL INTERSECTIONS REQUIRING SIDEWALKS. SLOPED SURFACES SHALL BE BROOM FINISHED TO PROVIDE TEXTURED NON-SLIP TYPE SURFACE, EXCEPT AS NOTED BELOW.
 2. CURB RAMP SHALL NOT BE POURED INTERNAL WITH SIDEWALK AND SHALL BE ISOLATED ON ALL SIDES BY CONSTRUCTION JOINTS.
 3. CURB RAMP SHALL HAVE A "DETECTABLE WARNING" SURFACE IN CONFORMANCE WITH LATEST EDITION OF ADA ACCESSIBILITY GUIDELINES (SEE DETECTABLE WARNING PATTERN DETAIL).

CURB RAMP SECTION DETAIL

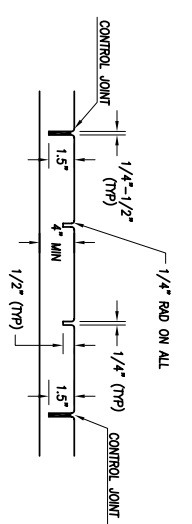
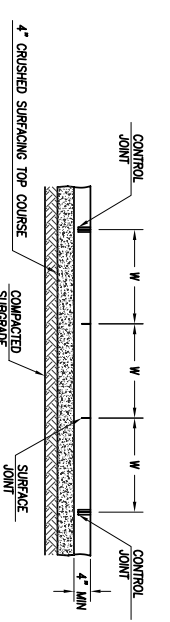
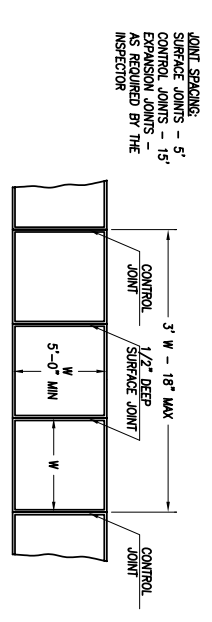

- NOTES:
1. CONCRETE SHALL BE 3000 PSI MIN COMMERCIAL CONCRETE.
 2. FINISH SHALL BE MEDIUM BROOM PERPENDICULAR TO PEDESTRIAN TRAFFIC UNLESS OTHERWISE DIRECTED.
 3. ALL EXISTING EDGES SHALL BE SAWCUT.
 4. ALL JOINTS AND EDGES SHALL BE FINISHED WITH 1/4\"/>

SIDEWALK DETAIL

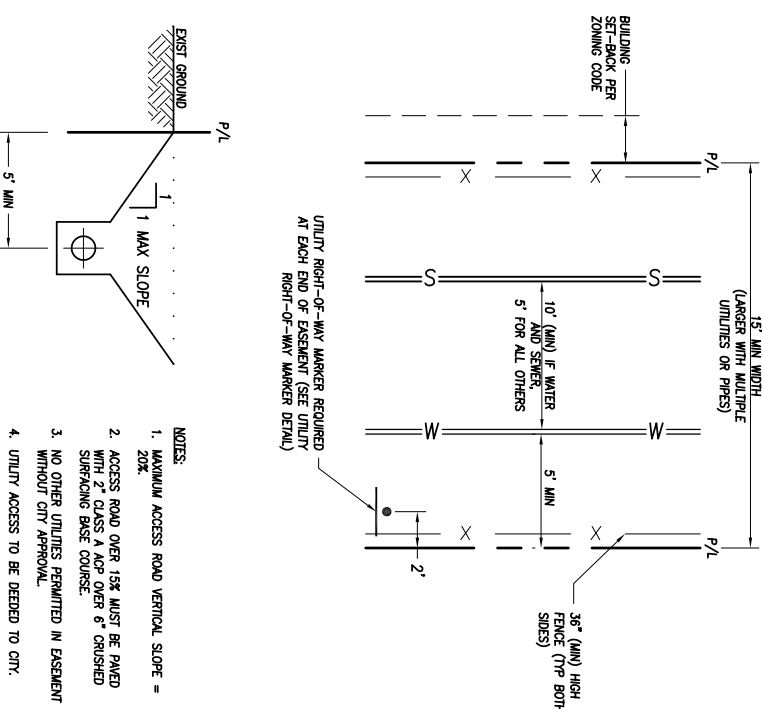

- NOTES:
1. MAXIMUM ACCESS ROAD VERTICAL SLOPE = 20%.
 2. ACCESS ROAD OVER 15% MUST BE PAVED WITH 2\"/>

BURIAL & SETBACK REQUIREMENT

OFF-STREET UTILITY RIGHT-OF-WAY

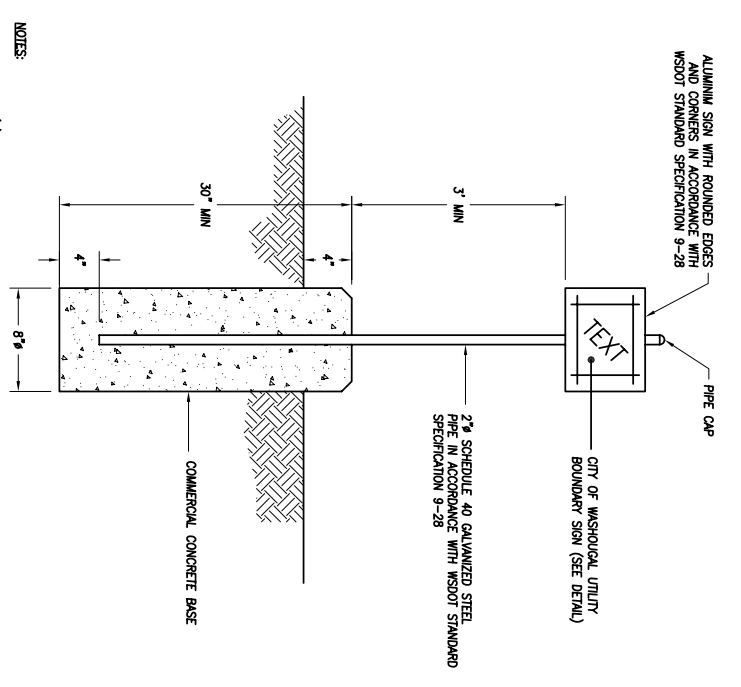

- NOTES:
1. MINIMUM OF (2) SIGNS REQUIRED.
 2. MAXIMUM SPACING 75' C/C.
 3. SIGNS TO BE PLACED ON BOUNDARY LINE WITHIN 3' OF PROPERTY CORNER.

UTILITY RIGHT-OF-WAY MARKER

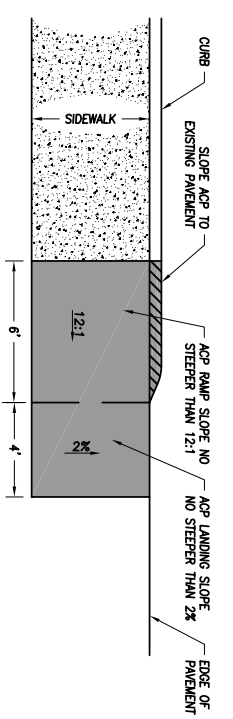

ATTACHED SIDEWALK

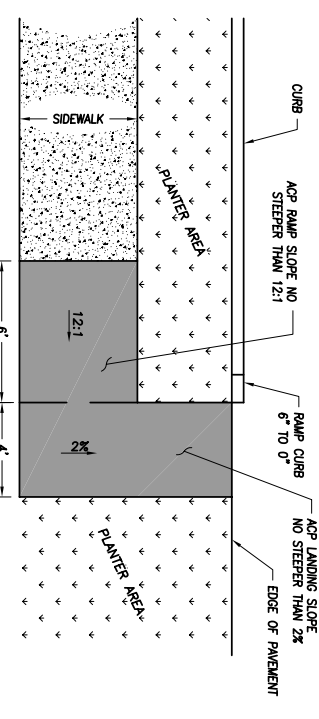

DETACHED SIDEWALK

- NOTES:
1. CLASS 2\"/>

TEMPORARY A/C RAMP

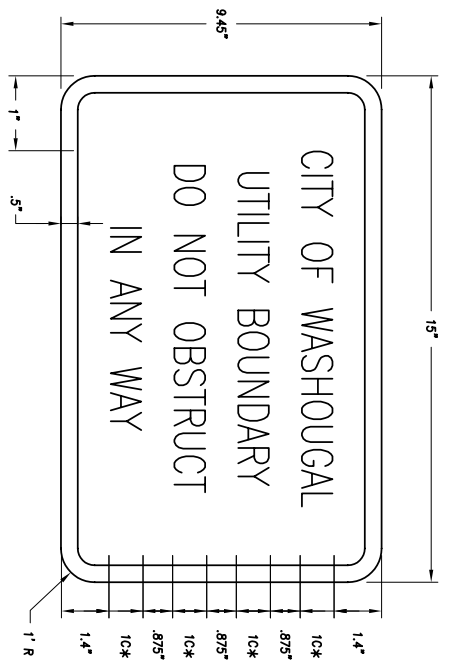

- NOTE:
- COLORS:
 LEGEND - WHITE (REFLECTIVE)
 BACKGROUND - GREEN
 * SERIES 2000 STANDARD ALPHABETS

STANDARD UTILITY BOUNDARY SIGN

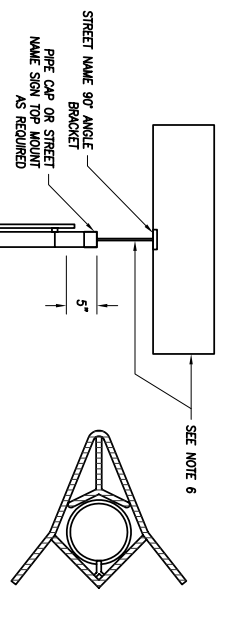

POST MOUNTING SOCKET

- NOTES:
1. HOT DIP GALVANIZE AFTER FABRICATION. STANDARD 2\"/>

PIPE SIGN SUPPORT DETAIL WITH POST MOUNTING SOCKET

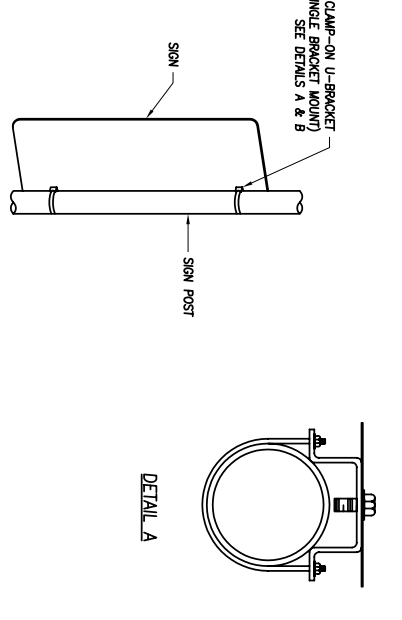

DETAIL A

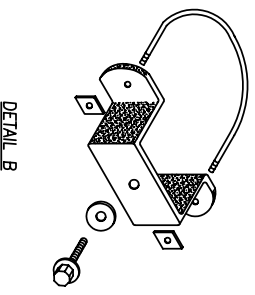

DETAIL B

- NOTE:
- BRACKET SYSTEM SHALL BE HEAVY ZINC COATED.

SINGLE BRACKET SIGN MOUNT DETAIL

| BY | DATE | NO. | APPROVED (CD) | VERSION |
|----|-------|-----|---------------|---------|
| MB | 8/03 | | APPROVED | 1.1 |
| MB | 10/03 | | APPROVED | 1.2 |

| DESIGNED | EA/UF | SCALE |
|----------|-------|-------|
| OSMAN | RS | |

| JOB NUMBER | DATE |
|------------|------|
| | |

CITY OF WASHOUGAL
 STANDARD TRANSPORTATION
 DETAILS - SHEET 1

| DRAWING NUMBER | SHEET | of |
|----------------|-------|----|
| | | |